

Occupational Safety and Health in the Construction of Water Supply Infrastructure in the Region of Lisbon and Surroundings, Portugal

Paulo Grave: Project Chief Engineer at EPAL-DPO - Lisbon, Portugal (pjgrave@epal.pt)

Célia Reis: Coordinator Engineer at EPAL-GIS - Lisbon, Portugal (celiadia@epal.pt)

Luís Bucha: Manager Engineer at EPAL-WCPT - Lisbon, Portugal (labucha@epal.pt)

Rui Santos: Safety and Health Coordinator at EPAL-DPO - Lisbon, Portugal (ruisant@epal.pt)

Luis Alves Dias: Professor at IST, Technical University of Lisbon, Portugal (luis.dias@civil.ist.utl.pt)

ABSTRACT

The construction of water related infrastructures in any part of the world involve many specific hazards, in special the risks related to cave-in. However, many other hazards are involved in these infrastructures, including those that are typical of most construction sites (e.g. fall from height, caught in/between, electrocution, etc.), but they may occur in different situations according to the specific nature and environment of each case. In this document, some construction projects and the associated safety and health issues implemented in practice are presented and discussed, in view to contribute to exchange the experiences on this subject matter, aiming to reduce the hazards in the construction of this type of infrastructures.

1 INTRODUCTION

The EPAL – Empresa Portuguesa das Águas Livres, SA (Portuguese company of the “free” waters) is a public company responsible for the water supply infrastructure for human consumption in the region of Lisbon and some surroundings, serving a population of about 3 million people in 35 counties in an area of about 7 million km². It is owned, at 100% stake, by AdP – Águas de Portugal (Waters of Portugal), a public holding company responsible for the water supply, sewage and solid waste at the national level.

Actually, the EPAL manages and explores a water supply system with a daily capacity production of over one million m³, including the transport and distribution extending along about 1900 km.

In view of the growing population and the inherent future demands of quality water supply, the company drew up an investment plan for the period until 2007 involving an amount of about 370 million Euros.

Most of this investment will favor the increase of the capacity of water capitation and production, the construction of new infrastructure and the renewal of the existing infrastructure of water supply, as well as the control and reduction of water losses along the network.

These improvements are underway and so, many of construction projects are being realized, where the safety and health issues assume a great importance due to the high risks involved in these kind of construction sites.

This document presents safety and health issues in some of the construction projects of EPAL.

2 SAFETY AND HEALTH AT EPAL

In all the construction projects of EPAL the requirements included in the legislation that transposes the Europe Union Directive 92/57/EEC is being applied.

In fact, since the year of 2000, a new methodology for the safety and health coordination during the design and execution phases has been implemented in EPAL based on the concepts of this Directive.

Meanwhile, in 2004, the AdP (the holding where EPAL is part of it) decided to draw up a “Manual for the Implementation of Safety and Health in Construction Projects” to be applied in the companies of the group (over 60) and for this purpose an external consultant was engaged.

Recently (end of 2004), the EPAL started to use this Manual as a basis for the implementation of safety and health coordination on their new construction projects and about 20 engineers have been qualified till now in safety and health coordination in specific courses (of about 250 hours).

Now, safety and health is being applied in all construction projects and in special in the most important and significant projects where the risks are highest. Some examples are presented in to next section.

3 IMPLEMENTATION OF SAFETY AND HEALTH IN CONSTRUCTION PROJECTS

The transposition of the Construction Sites (92/57/EEC) extends the Portuguese law relating to the protection of workers, by imposing several obligations to EPAL,SA, as an owner, for these larger and particular dangerous projects. The most important obligations are:

- Take into account the general principles of prevention under Health and Safety at Work Act in the design and execution phases of the construction project;
- Appointment of safety and health coordinators (for the design and for the execution phases);
- Preparation of a safety and health plan;
- Preparation of a safety and health file for subsequent work on the construction site;
- To approve the development of the safety and health plan to take into account the construction processes and methods implemented by the contractor;
- Prior notice of the construction site to the relevant authority (Labour Inspectorate);
- Regard the obligations of safety and health coordinator for the execution of the construction project, in the specific actions about the good practices in safety and health matters, namely the development of the safety and health plan (adjusted to the construction and elaborated by the contractor), as well as the adaptation and the complement of the safety and health file.

The safety and health plan includes, among other matters, the specific risks to deal with and the dangerous resulting from the development of several activities simultaneously, the safety measures to be taken as a result of the co-ordination measures and the applicable industrial safety regulations. The safety and health plan includes, essentially, the following sections:

- The risks to be expected for each task during the construction phase, both in relation to location and time;
- The necessary facilities and measures for prevention of these risks;
- The applicable industrial safety regulations;
- Supplement to the previous parts and further information for all participants, e.g. references to the texts of the invitations to tender, to positions in the specifications, plans and other documents applicable to the construction site and rules.

In the following subsections, some examples of the implementation of safety and health in construction projects under operation in EPAL are presented. They are: (i) the installation of an iron pipe under a railway line in operation; (ii) the construction of an equilibrium chimney; (iii) the construction of an underground water-tank; (iv) the construction of a water captation.

3.1 Installation of an iron pipe under a railway line in operation

3.1.1 Brief description of the project

According to what was referred in to above, EPAL, SA is now developing the construction of new infrastructure to increase the capacity of water captation and production. One of these projects involves the “Amplifying of the Subsystem of Castelo do Bode production capacity to 750.000 m³/day, with one first phase of 625.000 m³/day – Pipes – Lote II – Duplication of Section 1: Zone 1A - Meia Via”. This project includes the installation of an iron pipe, DN1800 mm, along, approximately, 7.500 meters, and a passage under a railway line in operation. To materialize this passage it was necessary to install 15 reinforced concrete pipes, DN2000 mm, each one with 2 meters long, using the method of “empushment”. After concluding the installation of these 15 pipes, then it was possible to insert the iron pipe DN1800 mm in its definitive position.

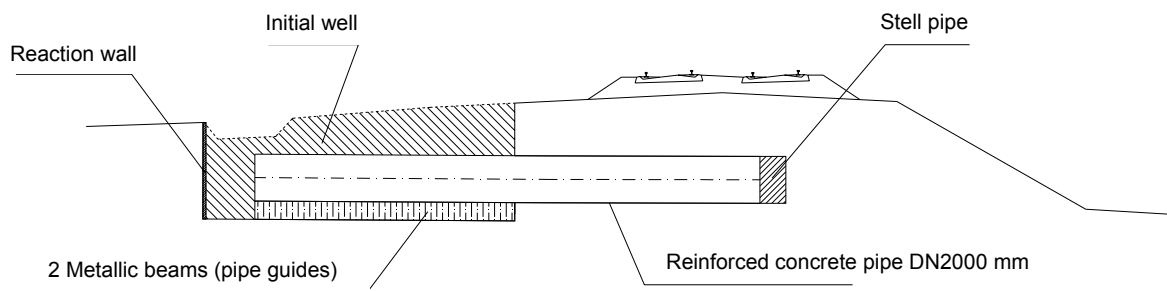

3.1.2 Main aspects related to specific actions of Construction Safety Coordination

Concerning safety and health in construction, the part of the project related with the passage under the railway line required special attention toward the minimization of risks to the workers involved in its development. In fact, this activity presents a potential (special) risk of cave in due to the possibility of land collapse, a risk that should be reduced.

Therefore, even in the early stage of the construction process, and with the intention to consider the application of some of the issues related with the General Principles of Prevention, it was establish that the passage in question will be materialized by using a methodology that reduces the risks that could not be totally eliminated. This preoccupation led to the implementation of the “empushment” method.

This method consists in the previous execution of a well to reach the intend level and to install the necessary equipment (Hydraulic Pusher) to do the operations required.

The work begins with the positioning of the first reinforced concrete pipe, DN2000 mm, whose extremity is placed against the slope, allowing the excavation by the inside. The operation of excavation is executed in parallel with the advancement of the pipe obtained by the functioning of the hydraulic equipment.

When the application of the first reinforced concrete pipe is finished, it starts the installation of the second one. The installation of the 15 pipes continues successively until they are completely positioned. The described procedure allowed doing the excavation operation in safety conditions despite the maintenance of the trains' traffic that only suffered velocity reductions (140 km/h to 50 km/h) also for safety precautions. It should be pointed out that the development of the solution described was based on several Monitoring and Prevention Plans that were very important in the information, training and responsibility of the workers involved in this operation.

3.2 Construction of an equilibrium chimney

3.2.1 Brief description of the project

The project "Amplifying of the Subsystem of Castelo do Bode production capacity to 750.000 m³/day, with one first phase of 625.000 m³/day – Pipes – Lote I – Elevation pipe" includes the installation in ditch of an iron pipe DN1800 mm, along, approximately, 9.000 meters, with a medium deep of 6 meters. This construction also includes the execution of a reinforced concrete equilibrium chimney with 27 meters high, 12 meters diameter and 0,30 meters thickness, located in a forest zone, destined to absorb variations of pressure inside de water main (protection system against hydraulic shock).

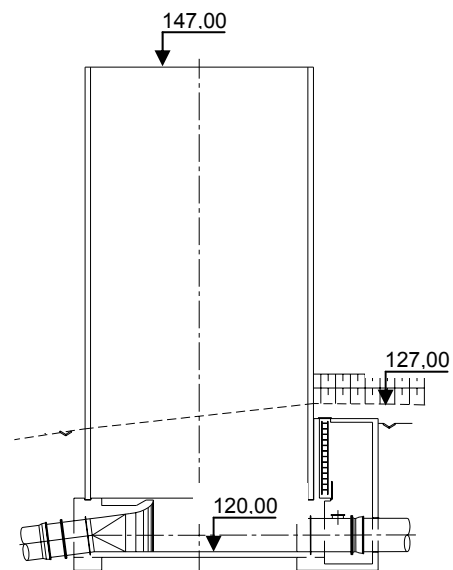

3.2.2 Main aspects related to specific actions of Construction Safety Coordination

This project ("construction of an equilibrium chimney") required two particular situations of special risks related to the construction of an equilibrium chimney and another two particular situations of special risks related to the installation of an iron pipe (DN1800 mm) and several organs (manoeuvre and control).

The two most significant risks related to the construction of an equilibrium chimney, are:

- Falling from a height;
- Applying of the preceding-effort.

Related to the measures for prevention of these risks, where they were particularly aggravated by the nature of the work or processes used, it was necessary to apply the following facilities and measures for prevention:

- Concerning the risk of falling from a height for the persons that work in the construction of vertical elements made of reinforced concrete, special care were taken as to the scaffoldings used;
- The measures for prevention of the risk associated to the use of fixed scaffoldings, consisted, essentially, in the application of modern scaffoldings, properly stabilized and equipped with adequate guardrails, as well as the realization of several actions of training and information for the workers, about the risks and preventive measures associated with the execution of these tasks;

- About the risks that result from the applying of the preceding-effort relate to construction of an equilibrium chimney built in a reinforced concrete structure, specific measures for prevention of these risks were considered, essentially, the two following situations: applying all the contents of a specific “work instruction” for that task (developed by the contractor and approved by the owner), as well as the realization of several actions of training and information for the workers on the risks and preventive measures associated to the realization of that task.

The two most significant risks related to the installation of an iron pipe (DN1800 mm) are:

- Cave in as a result of potential land collapse and falling from a height;
- The result of the use of digging, raising and transportation equipment nearest high voltage electric lines.

Related to the measures for prevention of these risks, where they were particularly aggravated by the nature of the work or processes used, it was necessary to apply the following measures:

- Concerning the risks of cave in by land collapse and falling from a height, for the workers involved in excavation works, the measures taken were essentially, to use slopes on excavations activities, as well as the applying of a specific collective protection system, on the peripheral area of excavation works (to prevent the risk of falling from a height).
- About the risks that result of raising, digging and transportation equipment nearest high voltage electric lines (mainly the risk of electrocution), the specific measures of prevention of that risk were, essentially, ensuring the use of equipment with electrical protection on the driver’s cabin, as well as the realization of several actions of training and information for the workers, about the risks and preventive measures associated to the realization of those tasks.

For both situations complementary measures were used, namely, the organization of several specific actions of training and information on the risks and preventive measures associated to the realization of those tasks. These actions involved all the workers concerned and were based on specific Monitoring and Prevention Plans. This allowed to obtain their co-responsibility and collaboration.

3.3 Construction of an underground water-tank

3.3.1 Brief description of the project

The construction of an underground water-tank, with 120 x 83 meters and 4,85 meters deep, and a capacity of 40.000 m³, is inserted in special works, whose objective is related to the construction of an enlargement of another underground water-tank with the same capacity.

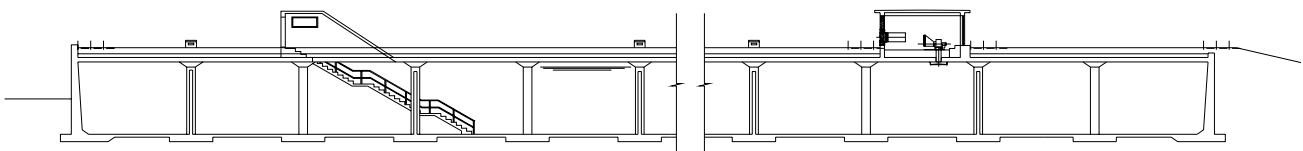

The main tasks include:

- ground move to set the foundations (concrete beds) of the water-tank, as well as some stretches of water iron pipes (DN1800 mm and DN1000 mm) and several organs (manoeuvre and control);
- reinforced concrete structures;

- coating and painting of walls, as well as horizontal and vertical elements made of reinforced concrete;
- links to the underground water-tank (that already exists) and links to several water pipes, that make a part of two important systems of EPAL,SA, for supplying water – “Adutor do Castelo do Bode” (pipe with DN1800 mm) and “Adutor do Médio Tejo” (pipe with DN1000 mm).

3.3.2 Main aspects related to specific actions of Construction Safety Coordination

This project (“construction of an underground water-tank”) involved two particular situations of special risks:

- Falling from a height;
- Falling of the covering flagstone (in a reinforced concrete structure) of the water-tank, during the drying period that follows the concrete application.

The measures implemented to face these risks, particularly aggravated by the nature of the work or processes used, were:

- Concerning the risk of falling from height (for persons working at the place of construction of horizontal and vertical elements made of reinforced concrete), special cares were taken as for the scaffoldings used, as well as with the borders and holes on the covering flagstone (in a reinforced concrete structure) of the water-tank;
- The measures for prevention of the risk associated with the use of fixed scaffoldings and mobile scaffoldings, consisted, essentially, in the application of modern scaffoldings, properly stabilized, and equipped with adequate guardrails. As for the measures for prevention of the risks associated with borders and holes on the covering flagstone, was considered the applying of adequate and complete guardrails.
- Related to the risk of falling the covering flagstone (in a reinforced concrete structure), during the period of drying, that follows the concrete application, the specific measures for prevention for this risk considered, essentially, two situations: - a correct calculation of the elements that support the covering flagstone of the water-tank, as well as an absolute interdiction of permanency of any person under the area of covering flagstone of the water-tank.

For both situations complementary measures were applied, namely, the organization of several specific actions of training and information involving all the workers concerned, allowing obtaining their co-responsibility and collaboration. Specific Monitoring and Prevention Plans were used as a basis for these actions.

3.4 Construction of a water captation

3.4.1 Brief description of the project

The project assigned “Remodeling of water intake plant of Valada-Tejo” contemplates the construction of a structure that allows the captation of 240.000 m³/day from the Tagus River, consisting of a prefabricated caisson with 22 x 5,7 meters and 11 meters high, placed in it’s definitive position by using the method of “Havage”. The frontal face of the structure supports four oscillating arms suction system (caption masts), DN700 mm, with 12 meters long, witch can rotate in the vertical plan, thanks to the lozenges (two for each mast) placed in the point of connection to the structure. Each captation element has an associated pump (FLYGT) that can elevate 933 l/s, allowing satisfying the captation needs with the simultaneous functioning of three pumps (2.800 l/s).

The caisson was made in 5 sections that were sunk sequentially by using “Havage” technology, allowing working even when the river level was high.

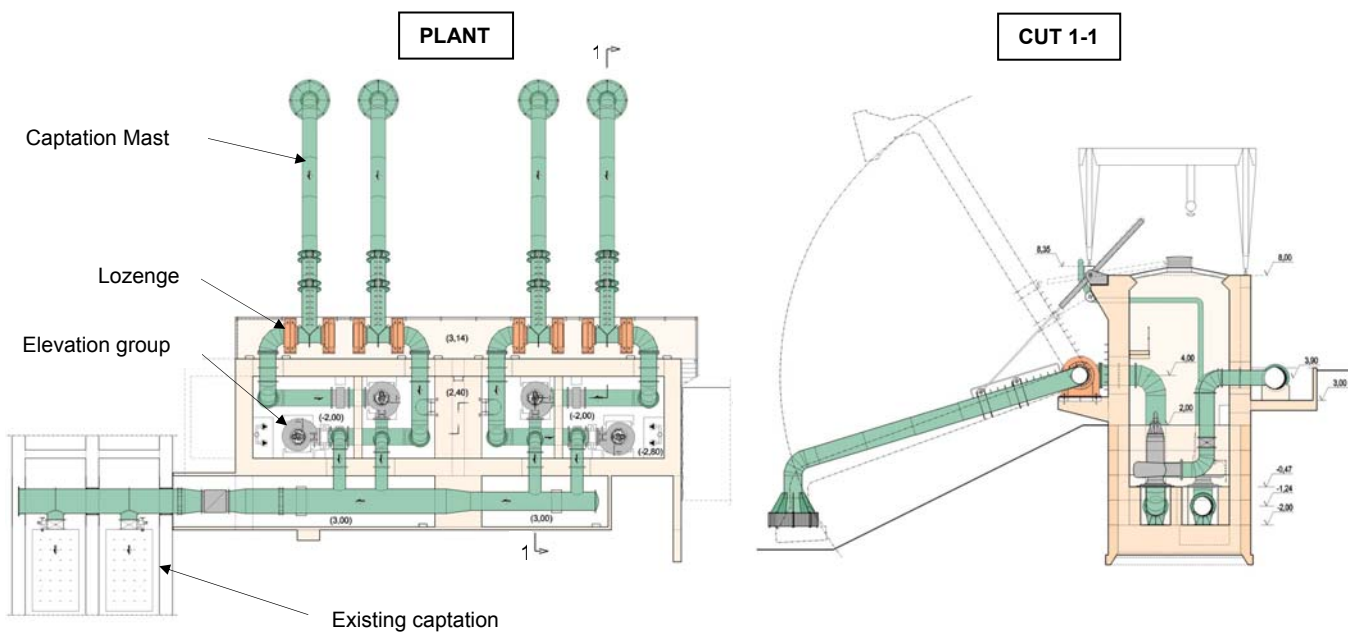
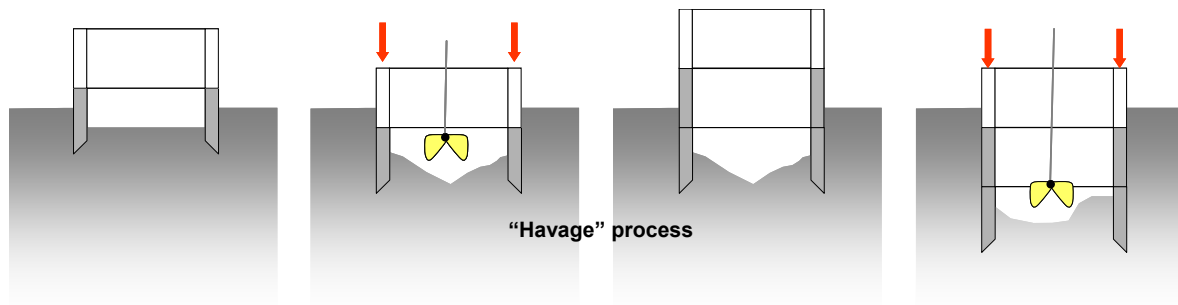

3.4.2 Main aspects related to specific actions of Construction Safety Coordination

This project (“construction of water captation”) had required two particular situations of special risks:

- Falling from a height;
- Flooding on construction area and drowning.

Related to the measures for prevention of these risks, particularly aggravated by the nature of the work or processes used, it was necessary to apply the following measures:

- Concerning the risk of falling from height for workers at the place of construction of horizontal and vertical elements of the prefabricated caisson in a reinforced concrete structure, special cares were taken as for the scaffoldings used, as well with the borders on the covering of that caisson.
- The measures for prevention of the risk associated for the use of fixed or mobile scaffoldings, consisted, essentially, in the application of modern scaffoldings, properly stabilized, and equipped with adequate guardrails; on the other hand,, as for the risks associated with the work near borders and holes on the covering flagstone, adequate and complete guardrails were used;

- As for the risk of flooding on construction area and drowning, a “stakes-plank” iron curtain was installed in the periphery of construction area, at the river side; however, this measure was insufficient, due the proximity of the river and the construction area. Since the water was always presents on the work area (until the construction of bottom flagstone, in a reinforced submerged concrete of the caisson), the main measures for prevention of the risk of drowning were: using mechanicals resources in the activities related with the excavation works, by the method of “Havage”, as well as reducing to a minimum the manual work during the period that the water was present on the work area (this situation was complemented with the placement, near that area, of a specific personal protection equipment to avoid drowning).

For both situations complementary measures were applied, namely, the organization of several specific actions of training and information involving all the workers concerned, allowing obtaining their co-responsibility and collaboration. Specific Monitoring and Prevention Plans were used as a basis for these actions.

4 CONCLUSIONS

The construction of water infrastructures includes many specific safety and health risks representing a real challenge for those involved in the construction of these projects (owners, designers, safety and health coordinators, contractors, workers).

The EPAL, as an owner, recognizes the importance of safety and health during all phases of their construction projects and puts a great emphasis on this issue by including specific safety and health requirements when tendering for the selection of designers and contractors, in particular to assure that the general principles of prevention are applied in all stages of the construction process. This is indeed an obligation that follows the provisions of the legislation that transposes the Construction Sites Directive (92/57/EEC).

During the construction phase, EPAL also assures the follow up of the implementation of the provisions of the safety and health plan through the supervisors and the safety and health coordinators that are nominated for each construction project.

On the other hand, EPAL is also responsible for maintaining all their water infrastructures and so the safety and health file is considered a very important document, which includes relevant safety and health information to be taken into account during the subsequent works. It good support on the maintenance works during the life cycle of these infrastructures.

The results achieved till now, while recording a significant reduction on the number of safety and health accidents and diseases, encourages EPAL to continue implementing and improve continuously the safety and health in all their construction projects.